

TW3967XF

TW3967XF Embedded Extended-Filter Triple-Band GNSS Antenna + L-Band

Frequency Coverage: GPS/QZSS-L1/L2/L5, GLONASS-G1/G2/G3, Galileo-E1/E5a/E5b, BeiDou-B1/B2/B2a, NavIC-L5
+L-band correction services

The TW3967XF is an embedded precision-tuned triple-band Accutenna[®] technology antenna providing coverage for triple-band GPS/QZSS-L1/L2/L5, GLONASS-G1/G2/G3, Galileo-E1/E5a/E5b, BeiDou-B1/B2/B2a, NavIC-L5, including the satellite-based augmentation system (SBAS) available in the region of operation [WAAS (North America), EGNOS (Europe), MSAS (Japan), or GAGAN (India)], plus L-Band correction services. It is especially designed for precision triple-frequency positioning.

The radio frequency spectrum has become more congested as new LTE bands are activated and their signals or harmonic frequencies [e.g. 800MHz x 2 = 1600MHz (GLONASS-G1)] can affect GNSS antennas and receivers. In North America, planned Ligado signals at 1525 - 1536 MHz can especially impact GNSS antennas that support space-based L-band correction services (1539 - 1559 MHz). New LTE signals in Europe [Band 32 (1452 - 1496 MHz)] and Japan [Bands 11 and 21 (1476 - 1511 MHz)] have also been observed to interfere with GNSS signals. In addition, Inmarsat satellite communication (uplink: 1626.5 - 1660.5 MHz) can also affect GNSS signals. The new Tallysman XF antennas have been designed to mitigate out-of-band signals and prevent GNSS antenna saturation. Tallysman's custom XF filtering mitigates all existing signals and new Ligado and LTE signals, enabling the antennas and attached GNSS receivers to perform optimally.

Ideal for autonomous vehicle tracking and guidance, precision agriculture, and other applications where precision matters, The TW3967XF provides superior multipath signal rejection, a linear phase response, and tight phase centre variation (PCV).

The TW3967XF features a precision-tuned, twin circular dual-feed, stacked patch element. The signals from the two orthogonal feeds are combined in a hybrid combiner, amplified in a wideband LNA, then band-split for narrow filtering in each band and further amplified prior to recombination at the output. The antenna also has a strong pre-filter to mitigate inter-modulated signal interference from Ligado, LTE and other cellular bands. The TW3967XF offers excellent axial ratio and a tightly grouped phase centre variation.

The standard TW3967 antenna (28 dB gain) and the low-gain extended-filter TW3967LGF antenna (20 dB gain) are also available.

 NavtechGPS

+1-703-256-8900 or 800-628-0885

info@NavtechGPS.com

www.NavtechGPS.com



Applications

- Autonomous vehicle tracking and guidance
- Triple-frequency RTK and PPP receivers
- Precision GNSS position
- Precision agriculture
- Network timing & synchronization
- Safety & security

Features

- Very low noise preamp (< 2.0 dB typ.)
- Low axial ratio (< 2.0 dB typ.)
- Tight phase centre variation
- LNA gain (28 dB typ.)
- Low current (45 mA typ.)
- ESD circuit protection (15 kV)
- Invariant performance from 2.5 to 16 VDC
- REACH and RoHS compliant

Benefits

- Excellent interference mitigation
- Excellent multipath rejection
- Increased system accuracy
- Excellent signal-to-noise ratio

TW3967XF Embedded Extended-Filter Triple-Band GNSS Antenna + L-Band

Frequency Coverage:

GPS/QZSS-L1/L2/L5, GLONASS-G1/G2/G3, Galileo-E1/E5a/E5b, BeiDou-B1/B2/B2a, NavIC-L5
+L-band correction services

Antenna

Technology: Dual-feed stacked RHCP ceramic patch

		Gain	Axial Ratio
		dBic typ. at Zenith	dB at Zenith
GNSS			
GPS / QZSS	L1	4.0	< 1.0
	L2	4.0	< 1.0
	L5	-1.5	< 1.5
GLONASS	G1	2.5	< 1.5
	G2	2.5	< 1.5
	G3	2.5	< 1.5
Galileo	E1	4.0	< 1.0
	E5a	-1.5	< 1.5
	E5b	2.5	< 1.5
	E6	-	-
BeiDou	B1	4.0	< 1.0
	B2	2.5	< 1.5
	B2a	-1.5	< 1.5
	B3	-	-
IRNSS / NavIC	L5	-1.5	< 1.5
QZSS	L6	-	-
L-band correction services		3.5	< 1.0
Satellite Communications			
Iridium		-	-
Globalstar		-	-
Other			
Axial Ratio at 10°	-	Efficiency	
Phase Centre Variation	± 10 mm		

Mechanicals

Mechanical Size	60 mm (dia.) x 14.9 mm (h.) [100 mm ground plane recommended]
Weight	70 g (excluding cable)
Available Connectors	see Ordering Guide
Radome / Enclosure	-
Mount	5 x M2 screws

Environmental

Operating Temperature	-40 °C to +85 °C
Storage Temperature	-55 °C to +95 °C
Mechanical Vibration	MIL-STD-810D Method 514.4 and 514.5
Shock and Drop	Vertical axis: 50 G, other axes: 30 G
Salt Fog	-
Low Pressure - Altitude	-
IP Rating (housing)	Not Applicable
Compliance	IPC-A-610, FCC, RED / CE Mark, RoHS, REACH

Warranty:

Parts and Labour: 1-year standard warranty

Low Noise Amplifier (LNA) - Measured at 3.0 VDC and 25°C

Frequency Bandwidth	Out-of-Band Rejection
Lower Band	1160 - 1255 MHz ≥ 70 dB @ ≤ 1050 MHz ≥ 65 dB @ ≤ 1125 MHz ≥ 70 dB @ ≥ 1350 MHz
L-band corrections services	1539 - 1559 MHz ≥ 65 dB @ ≤ 1500 MHz ≥ 45 dB @ ≤ 1525 MHz ≥ 30 dB @ ≤ 1536 MHz ≥ 65 dB @ ≥ 1650 MHz
Upper Band	1559 - 1606 MHz ≥ 65 dB @ ≤ 1500 MHz ≥ 45 dB @ ≤ 1525 MHz ≥ 30 dB @ ≤ 1536 MHz ≥ 65 dB @ ≥ 1650 MHz

Architecture	Pre-filter → LNA stage 1 → filter → LNA stage 2
Gain	28 dB typ.
Noise Figure	2.0 dB typ. @ 25 °C
VSWR	< 1.5:1 typ. 1.8:1 max.
Supply Voltage Range	2.5 to 16 VDC nominal, up to 50mV p-p ripple
Supply Current	45 mA typ. @ 25 °C,
ESD Circuit Protection	15 kV air discharge
P 1dB Output	5.1 dBm typ.
Group Delay Variation	12 ns @ (L1+G1) 7 ns @ (L5+L2+G2)
Group Delay	

Mechanical Diagram

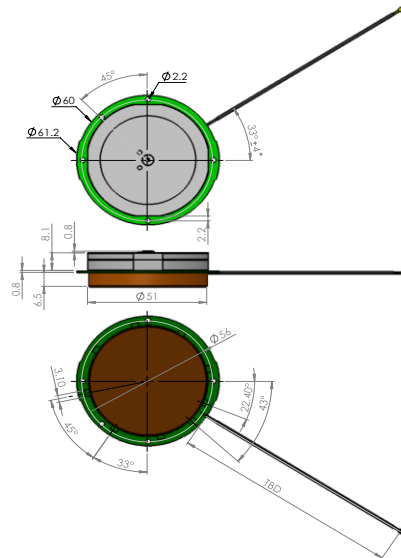

Ordering Information

Part Number: 33-3967XF-xx-yy-zzzz

Where xx = connector type, yy = shape and colour of radome and zzzz = cable length in mm (where applicable)

Please refer to our [Ordering Guide](https://www.tallysman.com/resource/tallysman-ordering-guide/) to review available radomes and connectors at: <https://www.tallysman.com/resource/tallysman-ordering-guide/>



Contact NavtechGPS for product details. www.NavtechGPS.com
+1-703-256-8900 • 800-628-0885 • info@navtechgps.com